

ROD WIPER CATALOGUE

Identification Charts
Press-Fit & Snap-In Styles
Metric & Imperial Sizes

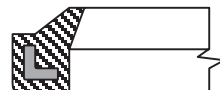

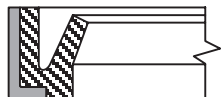

Phone (08) 9451 6011

Fax (08) 9458 5766

Index	Page
The Purpose Of Rod Wipers & Their Selection Criteria	1
Identifying Rod Wipers From Samples	1
Key To Proprietary Materials	1
Profile Chart : Rod Wipers & Scrapers	2
Metal Cased Rod Wipers : Standard Imperial Sizes	3-4
Metal Cased Rod Wipers : Standard Metric Sizes	5-6
Snap-In Rod Wipers : Standard Imperial Sizes	7-11
Snap-In Rod Scrapers : Standard Imperial & Standard Metric Sizes	11-12
Snap-In Rod Wipers : Standard Metric Sizes	13-15

The Purpose Of Rod Wipers & Their Selection Criteria

One of the most important factors affecting seal life in hydraulic and pneumatic rams is the exclusion of contamination from the operating system. This is achieved primarily through the use of rod wipers and rod scrapers. When selecting a rod wiper or rod scraper, you should keep the following general points in mind:

- A style should be selected that is suitable for the conditions in which the ram is expected to operate. For example, in extremely dirty conditions, thought should be given to a heavy duty metal cased rod wiper, or a rod scraper style.
- The machining processes required for press-fit metal cased styles are significantly simpler than those for snap-in styles. The time saved in the machine shop may make a metal cased wiper the most cost effective option available.
- The material from which the rod wiper is made should be compatible with both the system fluid, and the systems operating temperature range. Consult our technical staff if you are unsure of the appropriate choice.
- Most importantly, you should make a selection that is commonly available. To avoid future inconvenience, please confirm that the style & size of rod wiper or rod scraper in question are part of a standard stock range.

Identifying Rod Wipers From Samples

Identifying rod wipers from samples can be a difficult and confusing task. The procedure below will provide you with all the necessary information to specify your rod wiper over the phone.

Tip : The most accurate and easiest way to measure diameters **d** & **D** is from the actual rod and housing.

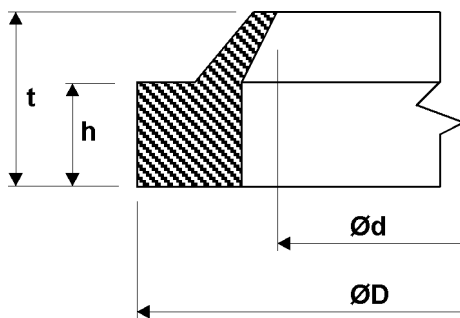

- | | | |
|---|-------------|---|
| 1 | Type | Specify the best match from the profiles on page 2. |
| 2 | Ød | Specify the actual rod diameter. |
| 3 | ØD | Specify the actual housing diameter, or wiper OD. |
| 4 | h | Specify the wipers height from base to shoulder. |
| 5 | t | Specify the wipers overall height. |

Key To Proprietary Materials

Note : Material May Vary

Rubber	Polyurethane	PTFE	Nylon	Metal



Profile Chart : Rod Wipers & Scrapers



The following profiles of common rod wipers are for identification purposes only. No reference is given as to sizes stocked for any style. Please verify the availability for your required style and size at the design stage of production.

Phone : (08) 9451 6011

Fax : (08) 9458 5766

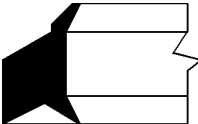
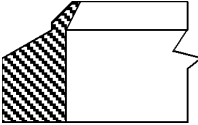
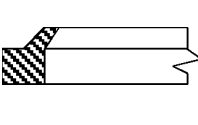
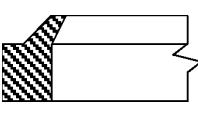
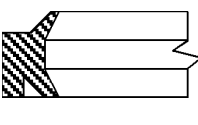
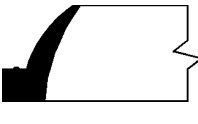
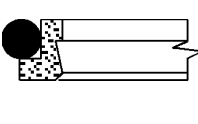
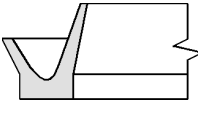
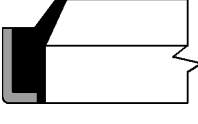
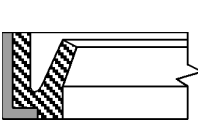
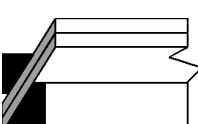
Metal Cased & Snap-In Designs : For Rod Use Only

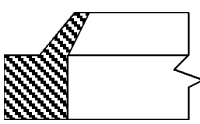
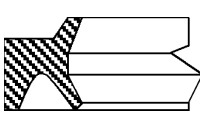
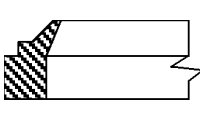
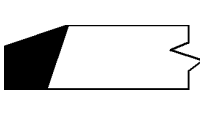
Profile	Style	Size Range
	NK	Imperial Sizes Only Light duty. Snap-in type. 41, UK, W, & K.
	UK	Imperial Sizes Only Light to medium duty. Snap-in type. 841 : Fits same groove as NK
	AN	Imperial Sizes Only Light to medium duty. Snap-in type. 421, 959 & 940.
	MW	Metric Sizes Only Light to medium duty. Snap-in type. 831, WRM & PW.
	JDH	Metric Sizes Only Light to medium duty. Snap-in type. 904 & DH.
	WO	Imperial Sizes Only Light to medium duty. Snap-in type. 841 & PWO.
	Z	Imperial & Metric Sizes Medium to heavy duty. Snap-in energized scraper type. High Temperature Range
	CSW	Imperial & Metric Medium to heavy duty. Snap-in scraper type. Metric sizes designated CSWM.
	MCW	Imperial & Metric Medium duty. Press-fit metal cased type. 905 & 37
	J	Imperial Sizes Only Medium to heavy duty. Press-fit metal cased type. 862 & MCW.
	S34	Imperial Sizes Only Heavy duty. Snap-in scraper type. Fits same groove as U

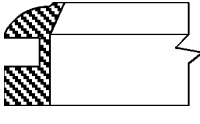
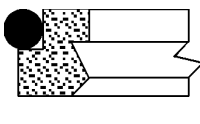
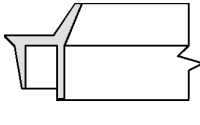
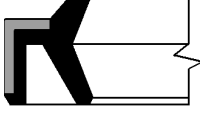
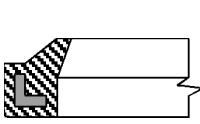
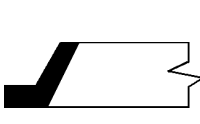
Profile	Style	Size Range
	U	Imperial Sizes Only Medium duty. Snap-in type. 520 & D.
	H	Imperial Sizes Only Light to medium duty. Snap-in type. 425 & 86.
	AA	Metric Sizes Only Light to medium duty. Snap-in type. 834, A1, PW/F & PWF
	RSC	Imperial Sizes Only Extra light duty. Snap-in type. 36, PWB & LDW.
	EW	Imperial & Metric Sizes Light to medium duty. Snap-in type. PWS & WRS.
	A6	Metric Sizes Only Medium duty. Snap-in-type.
	Y	Imperial & Metric Sizes Medium to heavy duty. Snap-in energized scraper type. High Temperature Range
	HSSM	Metric Sizes Only Medium to heavy duty. Snap-in scraper type. Fits same groove as CSWM.
	MCW	Metric Sizes Only Medium duty. Press-fit metal cased type. 913, 860 & DKB.
	MPW	Imperial & Metric Medium to heavy duty. Press-fit metal cased type. Metric sizes designated MMPW.
	DK	Metric Sizes Only Extra light duty. Snap-in type. MDK.



Phone (08) 9451 6011

Fax (08) 9458 5766

**Ensure Availability Before
Machining Or Design**

Light To Medium Duty

Metal Cased Rod Wipers : Style J

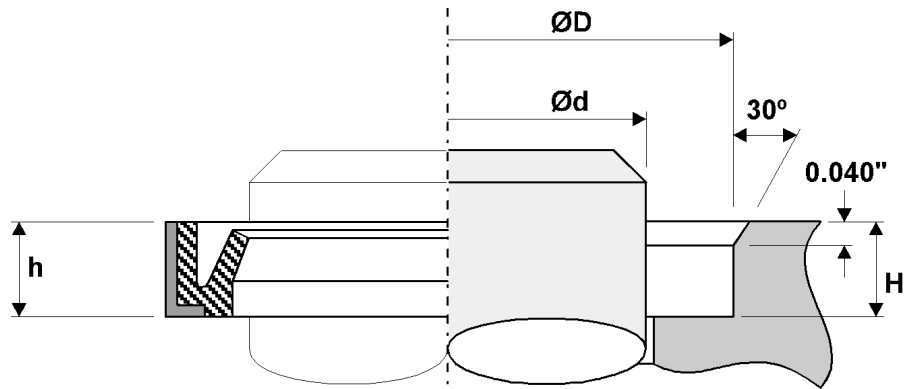

Product Code	Actual Size In Inches				Product Code	Actual Size In Inches			
	Ød	ØD	H	h		Ød	ØD	H	h
<i>Preferred Range</i>	Nom	+0.001 -0.001	+0.015 -0.000	Nom	<i>Preferred Range</i>	Nom	+0.001 -0.001	+0.015 -0.000	Nom
J0625	0.625	1.125	0.312	0.312	J2500	2.500	3.000	0.312	0.312
J0750	0.750	1.250	0.312	0.312	J2625	2.625	3.125	0.312	0.312
J0875	0.875	1.375	0.312	0.312	J2750	2.750	3.250	0.312	0.312
J1000	1.000	1.500	0.312	0.312	J3000	3.000	3.500	0.312	0.312
J1125	1.125	1.625	0.312	0.312	J3250	3.250	3.875	0.312	0.312
J1250	1.250	1.750	0.312	0.312	J3500	3.500	4.125	0.312	0.312
J1375	1.375	1.875	0.312	0.312	J3750	3.750	4.375	0.312	0.312
J1500	1.500	2.000	0.312	0.312	J4000	4.000	4.625	0.312	0.312
J1750	1.750	2.250	0.312	0.312	J4250	4.250	4.875	0.312	0.312
J1875	1.875	2.375	0.312	0.312	J4500	4.500	5.125	0.312	0.312
J2000	2.000	2.500	0.312	0.312	J4750	4.750	5.375	0.312	0.312
J2250	2.250	2.750	0.312	0.312	J5000	5.000	5.625	0.312	0.312
J2375	2.375	2.875	0.312	0.312	J6000	6.000	6.625	0.375	0.375

Metal Cased Rod Wipers : Style MCW (Style J Profile)

Product Code	Actual Size In Inches				Product Code	Actual Size In Inches			
	Ød	ØD	H	h		Ød	ØD	H	h
<i>Preferred Range</i>	Nom	+0.001 -0.001	+0.015 -0.000	Nom	<i>Preferred Range</i>	Nom	+0.001 -0.001	+0.015 -0.000	Nom
MCW087131X025	0.875	1.312	0.250	0.250	MCW350400X031	3.500	4.000	0.312	0.312
MCW150225X037	1.500	2.250	0.375	0.375	MCW350450X050	3.500	4.500	0.500	0.500
MCW175250X037	1.750	2.500	0.375	0.375	MCW375425X031	3.750	4.250	0.312	0.312
MCW200268X037	2.000	2.687	0.375	0.375	MCW400475X031	4.000	4.750	0.312	0.312
MCW200275X037	2.000	2.750	0.375	0.375	MCW400500X050	4.000	5.000	0.500	0.500
MCW225300X037	2.250	3.000	0.375	0.375	MCW425475X020	4.250	4.750	0.200	0.200
MCW250325X037	2.500	3.250	0.375	0.375	MCW450525X031	4.500	5.250	0.312	0.312
MCW275350X037	2.750	3.500	0.375	0.375	MCW450550X050	4.500	5.500	0.500	0.500
MCW275375X050	2.750	3.750	0.500	0.500	MCW500575X031	5.000	5.750	0.312	0.312
MCW300375X037	3.000	3.750	0.375	0.375	MCW625675X031	6.250	6.750	0.312	0.312
MCW300400X050	3.000	4.000	0.500	0.500	MCW675725X031	6.750	7.250	0.312	0.312
MCW325375X031	3.250	3.750	0.312	0.312	MCW812862X031	8.125	8.625	0.312	0.312



Phone (08) 9451 6011

Fax (08) 9458 5766

**Ensure Availability Before
Machining Or Design**

Medium Duty

Metal Cased Rod Wipers : Style MCW

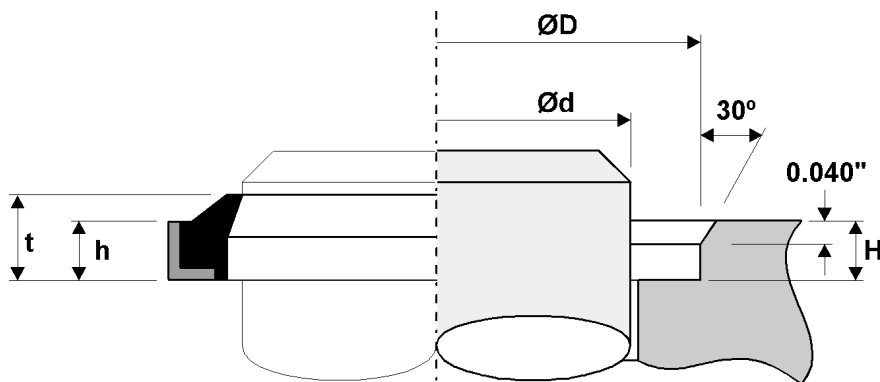

Product Code

Actual Size In Inches

Product Code

Actual Size In Inches

*Preferred
Range*

Ød	ØD	H	t
Nom	H8	+0.005 -0.005	Nom

*Preferred
Range*

Ød	ØD	H	t
Nom	H8	+0.005 -0.005	Nom

MCW075112-018-027	0.750	1.125	0.187	0.281	MCW175212-018-027	1.750	2.125	0.187	0.281
MCW087125-018-027	0.875	1.250	0.187	0.281	MCW200237-018-027	2.000	2.375	0.187	0.281
MCW100137-018-027	1.000	1.375	0.187	0.281	MCW225262-018-027	2.250	2.625	0.187	0.281
MCW112150-018-027	1.125	1.500	0.187	0.281	MCW250287-018-027	2.500	2.875	0.187	0.281
MCW125162-018-027	1.250	1.625	0.187	0.281	MCW275312-018-027	2.750	3.125	0.187	0.281
MCW150187-018-027	1.500	1.875	0.187	0.281	MCW300337-018-027	3.000	3.375	0.187	0.281
MCW162200-018	1.625	2.000	0.187	0.187	MCW400450-025-037	4.000	4.500	0.250	0.375

Metal Cased Rod Wipers : Style MPW

**Ensure Availability Before
Machining Or Design**

Medium To Heavy Duty

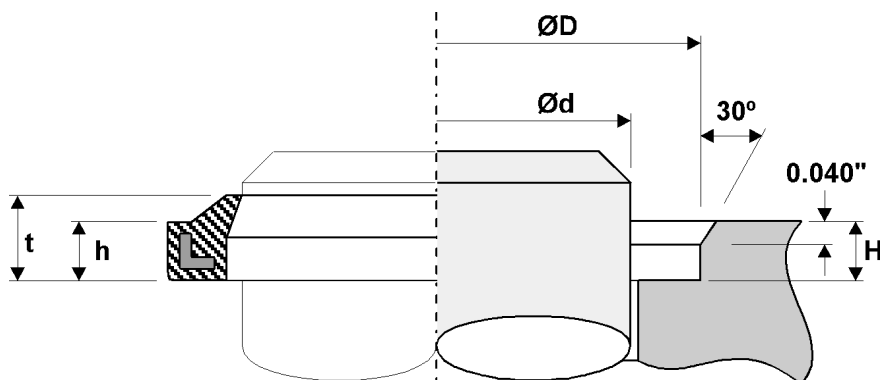

Product Code

Actual Size In Inches

Product Code

Actual Size In Inches

*Preferred
Range*

Ød	ØD	H	t
Nom	H8	+0.005 -0.005	Nom

*Preferred
Range*

Ød	ØD	H	t
Nom	H8	+0.005 -0.005	Nom

MPW00750	0.750	1.125	0.187	0.281	MPW02000	2.000	2.375	0.187	0.281
MPW01000	1.000	1.375	0.187	0.281	MPW02250	2.250	2.625	0.187	0.281
MPW01125	1.125	1.500	0.187	0.281	MPW02500	2.500	2.875	0.187	0.281
MPW01250	1.250	1.625	0.187	0.281	MPW02750	2.750	3.125	0.187	0.281
MPW01500	1.500	1.875	0.187	0.281	MPW03000	3.000	3.375	0.187	0.281
MPW01750	1.750	2.125	0.187	0.281	MPW04000	4.000	4.500	0.250	0.375



Phone (08) 9451 6011

Fax (08) 9458 5766

**Ensure Availability Before
Machining Or Design**

Light To Medium Duty

Metal Cased Rod Wipers : Style MCW

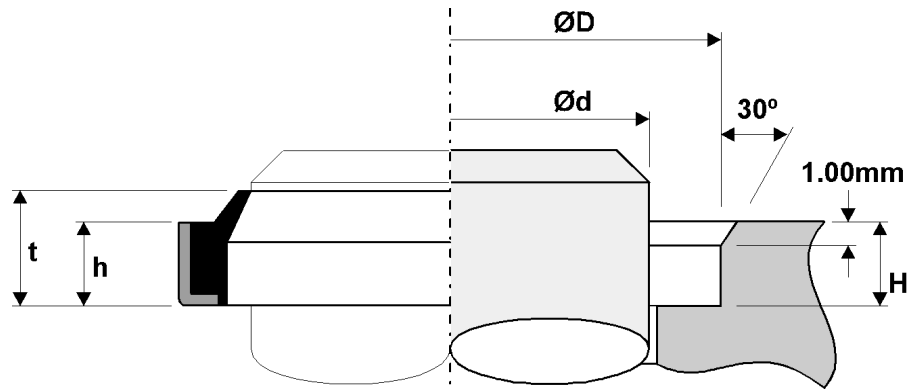

Product Code	Actual Size In mm				Product Code	Actual Size In mm			
	Ød	ØD	H	t		Ød	ØD	H	t
<i>Preferred Range</i>	Nom	H8	+0.10 -0.00	Nom	<i>Preferred Range</i>	Nom	H8	+0.10 -0.00	Nom
MCW1220X4-6	12.00	20.00	4.00	6.00	MCW5563X7-10	55.00	63.00	7.00	10.00
MCW1525X5-8	15.00	25.00	5.00	8.00	MCW5565X7-10	55.00	65.00	7.00	10.00
MCW1622X3-4	16.00	22.00	3.00	4.00	MCW5569X8-11	55.00	69.00	8.00	11.00
MCW1626X5-8	16.00	26.00	5.00	8.00	MCW5666X7-10	56.00	66.00	7.00	10.00
MCW1828X5-7	18.00	28.00	5.00	7.00	MCW6070X7-10	60.00	70.00	7.00	10.00
MCW1828X7-10	18.00	28.00	7.00	10.00	MCW6074X8-11	60.00	74.00	8.00	11.00
MCW2028X3-5-5	20.00	28.00	3.50	5.00	MCW6375X7-10	63.00	75.00	7.00	10.00
MCW2030X4-6	20.00	30.00	4.00	6.00	MCW6575X7-10	65.00	75.00	7.00	10.00
MCW2032X6-9	20.00	32.00	6.00	9.00	MCW6579X8-11	65.00	79.00	8.00	11.00
MCW2228X5-9	22.00	28.00	5.00	9.00	MCW7080X7-10	70.00	80.00	7.00	10.00
MCW2232X5-7	22.00	32.00	5.00	7.00	MCW7084X8-11	70.00	84.00	8.00	11.00
MCW2232X7-10	22.00	32.00	7.00	10.00	MCW7585X7-10	75.00	85.00	7.00	10.00
MCW2234X6-9	22.00	34.00	6.00	9.00	MCW7589X8-11	75.00	89.00	8.00	11.00
MCW2535X5-8	25.00	35.00	5.00	8.00	MCW7888X7-10	78.00	88.00	7.00	10.00
MCW2535X7-10	25.00	35.00	7.00	10.00	MCW8090X7-10	80.00	90.00	7.00	10.00
MCW2537X6-9	25.00	37.00	6.00	9.00	MCW8094X8-11	80.00	94.00	8.00	11.00
MCW2838X5-7	28.00	38.00	5.00	7.00	MCW8595X7-10	85.00	95.00	7.00	10.00
MCW3040X5-8	30.00	40.00	5.00	8.00	MCW8599X8-11	85.00	99.00	8.00	11.00
MCW3040X7-10	30.00	40.00	7.00	10.00	MCW90100X7-10	90.00	100.00	7.00	10.00
MCW3042X6-9	30.00	42.00	6.00	9.00	MCW90104X8-11	90.00	104.00	8.00	11.00
MCW3242X7-10	32.00	42.00	7.00	10.00	MCW95109X8-11	95.00	109.00	8.00	11.00
MCW3244X7-10	32.00	44.00	7.00	10.00	MCW100110X7-10	100.00	110.00	7.00	10.00
MCW3245X4-8	32.00	45.00	4.00	8.00	MCW100114X8-11	100.00	114.00	8.00	11.00
MCW3545X7-10	35.00	45.00	7.00	10.00	MCW105115X7-10	105.00	115.00	7.00	10.00
MCW3547X7-10	35.00	47.00	7.00	10.00	MCW110120X7-10	110.00	120.00	7.00	10.00
MCW3646X5-7	36.00	46.00	5.00	7.00	MCW110124X9-12	110.00	124.00	9.00	12.00
MCW3848X7-10	38.00	48.00	7.00	10.00	MCW110126X9-12	110.00	126.00	9.00	12.00
MCW4050X5-8	40.00	50.00	5.00	8.00	MCW115125X7-10	115.00	125.00	7.00	10.00
MCW4050X7-10	40.00	50.00	7.00	10.00	MCW115130X8-10	115.00	130.00	8.00	10.00
MCW4052X7-10	40.00	52.00	7.00	10.00	MCW115131X9-12	115.00	131.00	9.00	12.00
MCW4252X7-10	42.00	52.00	7.00	10.00	MCW115135X8-10	115.00	135.00	8.00	10.00
MCW4555X5-7	45.00	55.00	5.00	7.00	MCW120130X7-10	120.00	130.00	7.00	10.00
MCW4555X7-10	45.00	55.00	7.00	10.00	MCW120136X9-12	120.00	136.00	9.00	12.00
MCW4557X7-10	45.00	57.00	7.00	10.00	MCW125140X9-12	125.00	140.00	9.00	12.00
MCW4560X7-10	45.00	60.00	7.00	10.00	MCW125141X9-12	125.00	141.00	9.00	12.00
MCW5056X5-7	50.00	56.00	5.00	7.00	MCW130140X7-10	130.00	140.00	7.00	10.00
MCW5060X5-7	50.00	60.00	5.00	7.00	MCW130145X9-12	130.00	145.00	9.00	12.00
MCW5060X7-10	50.00	60.00	7.00	10.00	MCW130146X9-12	130.00	146.00	9.00	12.00
MCW5062X7-10	50.00	62.00	7.00	10.00	MCW140155X9-12	140.00	155.00	9.00	12.00
MCW5065X7-10	50.00	65.00	7.00	10.00	MCW140160X8-10	140.00	160.00	8.00	10.00



Phone (08) 9451 6011

Fax (08) 9458 5766

**Ensure Availability Before
Machining Or Design**

Medium Duty

Metal Cased Rod Wipers : Style MCW

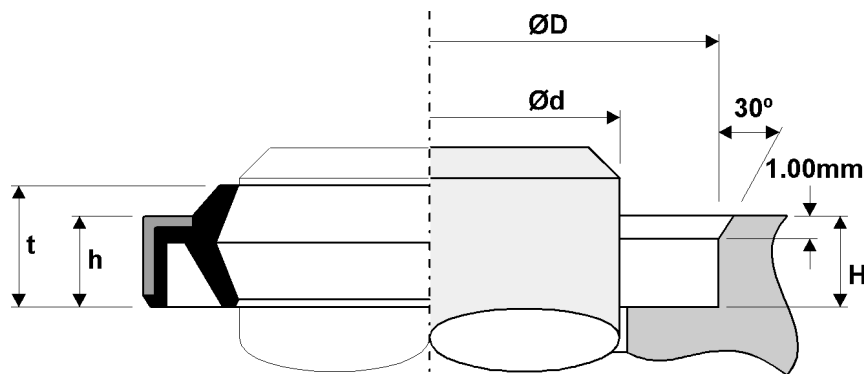

Product Code

Actual Size In Inches

Product Code

Actual Size In Inches

*Preferred
Range*

Ød	ØD	H	t
Nom	H8	+0.10 -0.00	Nom

*Preferred
Range*

Ød	ØD	H	t
Nom	H8	+0.10 -0.00	Nom

MCW140160X10-14	140.00	160.00	10.00	14.00	MCW170185X10-14	170.00	185.00	10.00	14.00
MCW150165X9-12	150.00	165.00	9.00	12.00	MCW180195X9-12	180.00	195.00	9.00	12.00
MCW150170X10-14	150.00	170.00	10.00	14.00	MCW190215X12-17	190.00	215.00	12.00	17.00
MCW160175X9-12	160.00	175.00	9.00	12.00	MCW200220X12-16	200.00	220.00	12.00	16.00
MCW160180X5-6	160.00	180.00	5.00	6.00	MCW200225X12-17	200.00	225.00	12.00	17.00

Metal Cased Rod Wipers : Style MMPW

**Ensure Availability Before
Machining Or Design**

Medium To Heavy Duty

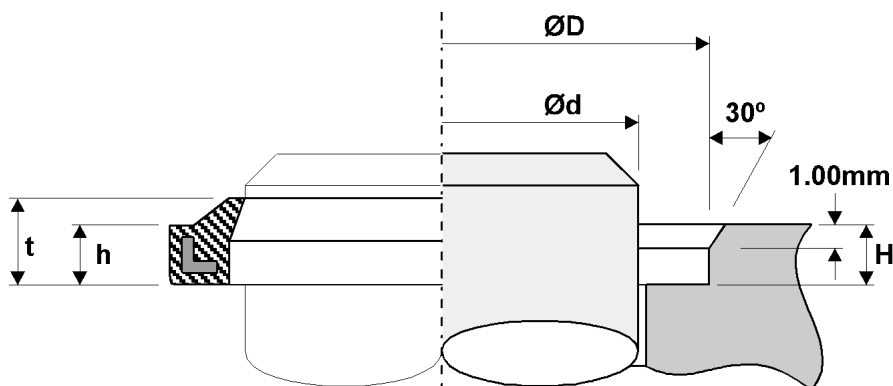

Product Code

Actual Size In Inches

Product Code

Actual Size In Inches

*Preferred
Range*

Ød	ØD	H	t
Nom	H8	+0.10 -0.00	Nom

*Preferred
Range*

Ød	ØD	H	t
Nom	H8	+0.10 -0.00	Nom

MMPW0160	16.00	22.00	3.00	5.00	MMPW0650	65.00	75.00	7.00	10.00
MMPW0200	20.00	30.00	5.00	8.00	MMPW0700	70.00	80.00	7.00	10.00
MMPW0250	25.00	35.00	5.00	8.00	MMPW0800	80.00	90.00	7.00	10.00
MMPW0300	30.00	40.00	5.00	8.00	MMPW1000	100.00	110.00	7.00	10.00
MMPW0350	35.00	45.00	7.00	10.00	MMPW1100	110.00	120.00	7.00	10.00
MMPW0400	40.00	50.00	7.00	10.00	MMPW1250	125.00	140.00	9.00	12.00
MMPW0450	45.00	55.00	7.00	10.00	MMPW1400	140.00	155.00	9.00	12.00
MMPW0500	50.00	60.00	7.00	10.00	MMPW1600	160.00	175.00	9.00	12.00
MMPW0550	55.00	65.00	7.00	10.00	MMPW1650	165.00	180.00	9.00	12.00
MMPW0600	60.00	70.00	7.00	10.00	MMPW1750	175.00	190.00	9.00	12.00



Phone (08) 9451 6011

Fax (08) 9458 5766

**Ensure Availability Before
Machining Or Design**

Light To Medium Duty

Snap-In Rod Wipers : Style NK

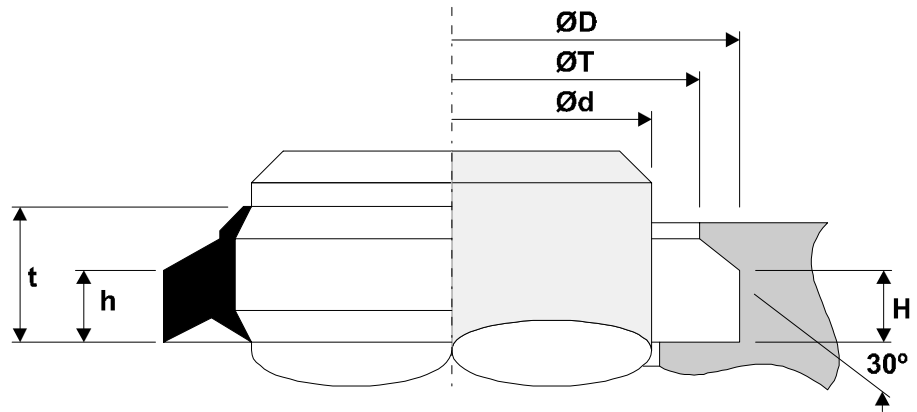

Style NK	Product Code		Actual Size In Inches					
	Style UK	Style VK	Ød	ØD	ØT	H	t	
Nitrile	Urethane	Viton	Nominal	+0.005 -0.000	+0.010 -0.000	+0.005 -0.000	Nominal	
NK0500	-	-	0.500	0.750	0.608	0.176	0.275	
NK0625A	-	-	0.625	0.875	0.733	0.176	0.275	
NK0625	UK0625	-	0.625	1.000	0.733	0.188	0.350	
NK0750A	-	-	0.750	1.000	0.858	0.176	0.275	
NK0750	UK0750	-	0.750	1.125	0.858	0.188	0.350	
NK0875A	-	-	0.875	1.125	0.983	0.176	0.275	
NK0875	UK0875	-	0.875	1.250	0.983	0.188	0.350	
NK1000A	-	VK1000A	1.000	1.250	1.108	0.176	0.275	
NK1000	UK1000	-	1.000	1.375	1.108	0.188	0.350	
NK1125	UK1125	-	1.125	1.500	1.233	0.188	0.350	
NK1250A	-	-	1.250	1.500	1.358	0.176	0.275	
NK1250	UK1250	-	1.250	1.625	1.358	0.188	0.350	
NK1375	UK1375	VK1375	1.375	1.750	1.483	0.188	0.350	
NK1500A	-	-	1.500	1.750	1.608	0.176	0.275	
NK1500	UK1500	VK1500	1.500	1.875	1.608	0.188	0.350	
NK1625	-	-	1.625	2.000	1.733	0.188	0.350	
NK1750	UK1750	VK1750	1.750	2.125	1.858	0.188	0.350	
NK1875	UK1875	-	1.875	2.250	1.983	0.188	0.350	
NK2000A	-	VK2000A	2.000	2.250	2.108	0.176	0.275	
NK2000	UK2000	VK2000	2.000	2.375	2.108	0.188	0.350	
NK2125	-	-	2.125	2.650	2.315	0.250	0.450	
NK2250	UK2250	-	2.250	2.775	2.440	0.250	0.450	
NK2375	-	-	2.375	2.900	2.565	0.250	0.450	
NK2500A	-	-	2.500	2.875	2.690	0.188	0.350	
NK2500	UK2500	-	2.500	3.025	2.690	0.250	0.450	
NK2625	UK2625	-	2.625	3.150	2.815	0.250	0.450	
NK2750	UK2750	-	2.750	3.250	2.940	0.250	0.450	
NK3000	UK3000	VK3000	3.000	3.525	3.190	0.250	0.450	
NK3125	-	-	3.125	3.650	3.315	0.250	0.450	
NK3250	UK3250	-	3.250	3.750	3.440	0.250	0.450	
NK3375	-	-	3.375	3.900	3.565	0.250	0.450	
NK3500	UK3500	VK3500	3.500	4.025	3.690	0.250	0.450	
NK3750	-	-	3.750	4.275	3.940	0.250	0.450	
NK4000	UK4000	VK4000	4.000	4.525	4.190	0.250	0.450	
NK4250	-	-	4.250	4.775	4.440	0.250	0.450	
NK4500	-	-	4.500	5.025	4.690	0.250	0.450	
NK5000	-	VK5000	5.000	5.525	5.190	0.250	0.450	
NK5250	-	-	5.250	5.775	5.440	0.250	0.450	
NK5500	-	-	5.500	6.025	5.690	0.250	0.450	
NK6000	-	-	6.000	6.525	6.190	0.250	0.450	
EXT280	-	-	Extrusion equivalent to NK6000 for sizes above 6.000".					



Phone (08) 9451 6011

Fax (08) 9458 5766

**Ensure Availability Before
Machining Or Design**

Medium Duty

Snap-In Rod Wipers : Style U

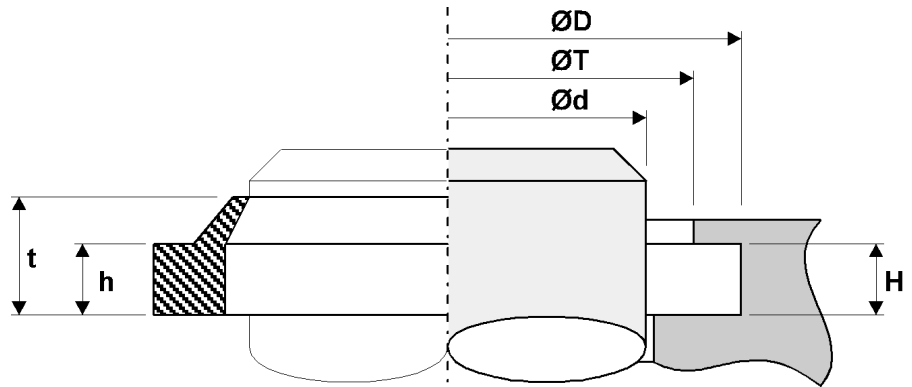

Product Code	Actual Size In Inches				Product Code	Actual Size In Inches			
	Ød	ØD	ØT	H		Ød	ØD	ØT	H
<i>Preferred Range</i>	Nom	+0.003 -0.003	+0.010 -0.000	+0.004 -0.000	<i>Preferred Range</i>	Nom	+0.003 -0.003	+0.010 -0.000	+0.004 -0.000
U0250	0.250	0.500	0.410	0.124	U4000	4.000	4.500	4.327	0.249
U0312	0.312	0.563	0.475	0.124	U4125	4.125	4.625	4.452	0.249
U0375	0.375	0.625	0.535	0.124	U4250	4.250	4.750	4.577	0.249
U0437	0.437	0.688	0.600	0.124	U4375	4.375	4.875	4.702	0.249
U0500	0.500	0.750	0.660	0.124	U4500	4.500	5.250	4.993	0.374
U0562	0.562	0.813	0.725	0.124	U4625	4.625	5.375	5.118	0.374
U0625	0.625	0.875	0.785	0.124	U4750	4.750	5.500	5.243	0.374
U0687	0.687	0.938	0.850	0.124	U4875	4.875	5.625	5.368	0.374
U0750	0.750	1.125	0.995	0.187	U5000	5.000	5.750	5.493	0.374
U0812	0.812	1.188	1.060	0.187	U5125	5.125	5.875	5.618	0.374
U0875	0.875	1.250	1.120	0.187	U5250	5.250	6.000	5.743	0.374
U0937	0.937	1.313	1.185	0.187	U5375	5.375	6.125	5.868	0.374
U1000	1.000	1.375	1.245	0.187	U5500	5.500	6.250	5.993	0.374
U1062	1.062	1.438	1.310	0.187	U5625	5.625	6.375	6.118	0.374
U1125	1.125	1.500	1.370	0.187	U5750	5.750	6.500	6.243	0.374
U1187	1.187	1.563	1.435	0.187	U6000	6.000	6.750	6.493	0.374
U1250	1.250	1.625	1.495	0.187	U6250	6.250	7.000	6.743	0.374
U1375	1.375	1.750	1.620	0.187	U6375	6.375	7.125	6.868	0.374
U1500	1.500	1.875	1.745	0.187	U6500	6.500	7.250	6.993	0.374
U1625	1.625	2.000	1.870	0.187	U6750	6.750	7.500	7.243	0.374
U1750	1.750	2.125	1.995	0.187	U6875	6.875	7.625	7.368	0.374
U1875	1.875	2.250	2.120	0.187	U7000	7.000	7.750	7.493	0.374
U2000	2.000	2.500	2.327	0.249	U7250	7.250	8.000	7.743	0.374
U2125	2.125	2.625	2.452	0.249	U7500	7.500	8.250	7.993	0.374
U2250	2.250	2.750	2.577	0.249	U7750	7.750	8.500	8.243	0.374
U2375	2.375	2.875	2.702	0.249	U8000	8.000	8.750	8.493	0.374
U2500	2.500	3.000	2.827	0.249	U8250	8.250	9.000	8.743	0.374
U2562	2.562	3.063	2.890	0.249	U8500	8.500	9.250	8.993	0.374
U2625	2.625	3.125	2.952	0.249	U8750	8.750	9.500	9.243	0.374
U2750	2.750	3.250	3.077	0.249	U9000	9.000	9.750	9.493	0.374
U2875	2.875	3.375	3.202	0.249	U9500	9.500	10.250	9.993	0.374
U3000	3.000	3.500	3.327	0.249	U9750	9.750	10.500	10.243	0.374
U3125	3.125	3.625	3.452	0.249	U10000	10.000	11.000	10.659	0.499
U3250	3.250	3.750	3.577	0.249	U10250	10.250	11.250	10.909	0.499
U3375	3.375	3.875	3.702	0.249	U10500	10.500	11.500	11.159	0.499
U3500	3.500	4.000	3.827	0.249	U11000	11.000	12.000	11.659	0.499
U3625	3.625	4.125	3.952	0.249	U11500	11.500	12.500	12.159	0.499
U3750	3.750	4.250	4.077	0.249	U12000	12.000	13.000	12.659	0.499
U3875	3.875	4.375	4.202	0.249	U13750	13.750	14.750	14.409	0.499



Phone (08) 9451 6011

Fax (08) 9458 5766

**Ensure Availability Before
Machining Or Design**

Light To Medium Duty

Snap-In Rod Wipers : Style AN

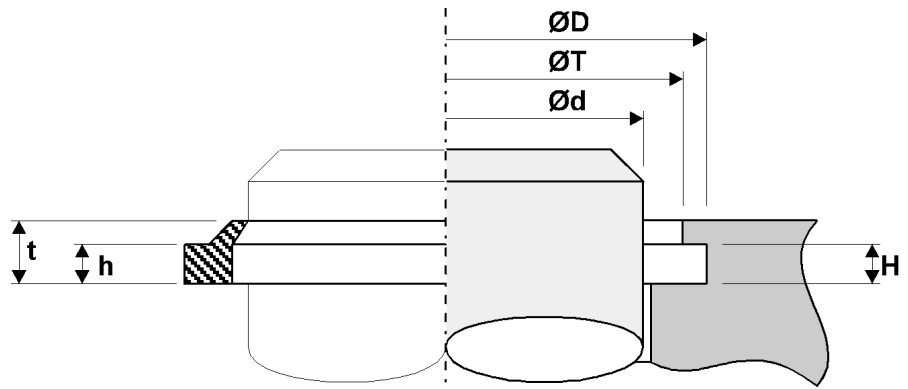

Product Code	Actual Size In Inches				Product Code	Actual Size In Inches			
	Ød	ØD	ØT	H		Ød	ØD	ØT	H
<i>Non-Preferred Range</i>	Nom	+0.004 -0.000	+0.005 -0.000	+0.003 -0.003	<i>Non-Preferred Range</i>	Nom	+0.004 -0.000	+0.005 -0.000	+0.003 -0.003
AN0500	0.500	0.760	0.647	0.107	AN3500	3.500	3.864	3.709	0.122
AN0562	0.562	0.823	0.710	0.107	AN3625	3.625	3.989	3.834	0.122
AN0625	0.625	0.885	0.772	0.107	AN3750	3.750	4.114	3.959	0.122
AN0687	0.687	0.948	0.834	0.107	AN3875	3.875	4.239	4.084	0.122
AN0750	0.750	1.010	0.897	0.107	AN4000	4.000	4.427	4.240	0.138
AN0812	0.812	1.084	0.960	0.107	AN4125	4.125	4.552	4.365	0.138
AN0875	0.875	1.147	1.023	0.107	AN4250	4.250	4.677	4.490	0.138
AN0937	0.937	1.209	1.085	0.107	AN4375	4.375	4.802	4.615	0.138
AN1000	1.000	1.272	1.148	0.107	AN4500	4.500	4.927	4.740	0.138
AN1062	1.062	1.334	1.210	0.107	AN4625	4.625	5.052	4.865	0.138
AN1125	1.125	1.397	1.273	0.107	AN4750	4.750	5.177	4.990	0.138
AN1187	1.187	1.459	1.335	0.107	AN4875	4.875	5.302	5.115	0.138
AN1250	1.250	1.522	1.398	0.107	AN5000	5.000	5.427	5.240	0.138
AN1312	1.312	1.614	1.480	0.107	AN5125	5.125	5.552	5.365	0.138
AN1375	1.375	1.677	1.542	0.107	AN5250	5.250	5.677	5.490	0.138
AN1437	1.437	1.739	1.605	0.107	AN5375	5.375	5.802	5.615	0.138
AN1500	1.500	1.802	1.668	0.107	AN5500	5.500	5.927	5.740	0.138
AN1562	1.562	1.865	1.731	0.107	AN5625	5.625	6.114	5.896	0.154
AN1625	1.625	1.927	1.793	0.107	AN5750	5.750	6.239	6.022	0.154
AN1750	1.750	2.052	1.918	0.107	AN5875	5.875	6.364	6.146	0.154
AN1812	1.812	2.115	1.981	0.107	AN6000	6.000	6.489	6.272	0.154
AN1875	1.875	2.177	2.043	0.107	AN6250	6.250	6.739	6.522	0.154
AN2000	2.000	2.302	2.178	0.107	AN6500	6.500	6.989	6.772	0.154
AN2062	2.062	2.365	2.241	0.107	AN6750	6.750	7.239	7.022	0.154
AN2125	2.125	2.427	2.303	0.107	AN7000	7.000	7.489	7.272	0.154
AN2250	2.250	2.552	2.428	0.107	AN7250	7.250	7.739	7.522	0.154
AN2312	2.312	2.615	2.491	0.107	AN7500	7.500	7.989	7.772	0.154
AN2375	2.375	2.677	2.553	0.107	AN7750	7.750	8.239	8.022	0.154
AN2437	2.437	2.740	2.616	0.107	AN8000	8.000	8.489	8.272	0.154
AN2500	2.500	2.802	2.678	0.107	AN8125	8.125	8.614	8.397	0.154
AN2562	2.562	2.865	2.741	0.107	AN8500	8.500	8.989	8.772	0.154
AN2625	2.625	2.989	2.834	0.122	AN9000	9.000	9.489	9.272	0.154
AN2750	2.750	3.114	2.959	0.122	AN9500	9.500	9.989	9.772	0.154
AN2875	2.875	3.239	3.084	0.122	AN10000	10.000	10.489	10.272	0.154
AN3000	3.000	3.364	3.209	0.122	AN10750	10.750	11.239	11.022	0.154
AN3125	3.125	3.489	3.334	0.122	AN11000	11.000	11.489	11.272	0.154
AN3250	3.250	3.614	3.459	0.122	AN11500	11.500	11.989	11.772	0.169
AN3375	3.375	3.739	3.584	0.122					



Phone (08) 9451 6011

Fax (08) 9458 5766

**Ensure Availability Before
Machining Or Design**

Light To Medium Duty

Snap-In Rod Wipers : Style H

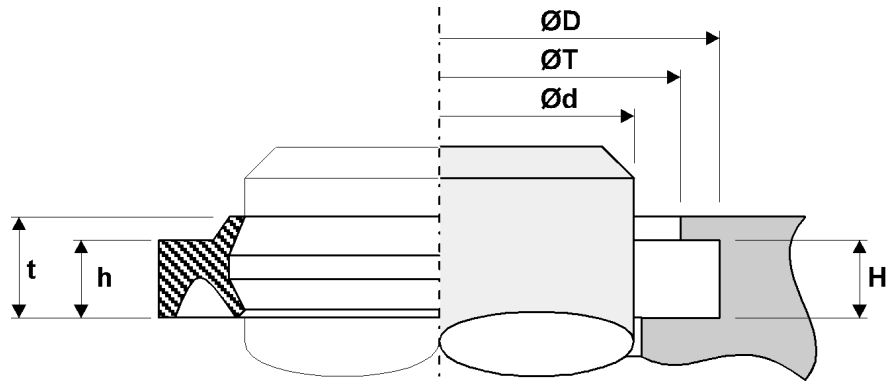

Product Code	Non-Preferred Range	Actual Size In Inches				
		Ød	ØD	ØT	H	t
Nitrile	Urethane	Nominal	+0.003 -0.003	+0.003 -0.003	+0.005 -0.000	Nominal
H0500N8	-	0.500	0.802	0.620	0.203	0.240
H0625N8	-	0.625	0.927	0.745	0.203	0.240
H0750N8	-	0.750	1.052	0.870	0.203	0.240
H0875N8	-	0.875	1.240	1.010	0.218	0.240
H1000N8	H1000U9	1.000	1.365	1.135	0.218	0.275
H1250N8	H1250U9	1.250	1.615	1.385	0.218	0.275
H1375N8	H1375U9	1.375	1.740	1.510	0.218	0.275
H1500N8	H1500U9	1.500	1.865	1.635	0.218	0.275
H1750N8	H1750U9	1.750	2.115	1.885	0.218	0.275
H2000N8	H2000U9	2.000	2.365	2.135	0.218	0.275
H2250N8	H2250U9	2.250	2.745	2.385	0.281	0.340
H2500N8	H2500U9	2.500	2.995	2.635	0.281	0.340
H2750N8	H2750U9	2.750	3.245	2.885	0.281	0.340
H3000N8	H3000U9	3.000	3.495	3.135	0.281	0.340
H3250N8	H3250U9	3.250	3.745	3.385	0.281	0.340
H3500N8	H3500U9	3.500	3.995	3.635	0.281	0.340
H4000N8	H4000U9	4.000	4.495	4.135	0.281	0.340
H4375N8	-	4.375	4.870	4.510	0.281	0.340
-	H4500U9	4.500	4.995	4.635	0.281	0.340
-	H4750U9	4.750	5.245	4.885	0.281	0.340
-	H5000U9	5.000	5.495	5.135	0.281	0.340
H5500N8	H5500U9	5.500	5.995	5.635	0.281	0.340
H6000N8	-	6.000	6.495	6.135	0.281	0.340
H7750N8	-	7.750	8.245	7.885	0.281	0.340
H9750N8	-	9.750	10.245	9.885	0.281	0.340



Phone (08) 9451 6011

Fax (08) 9458 5766

**Ensure Availability Before
Machining Or Design**

Light To Medium Duty

Snap-In Rod Wipers : Style WO

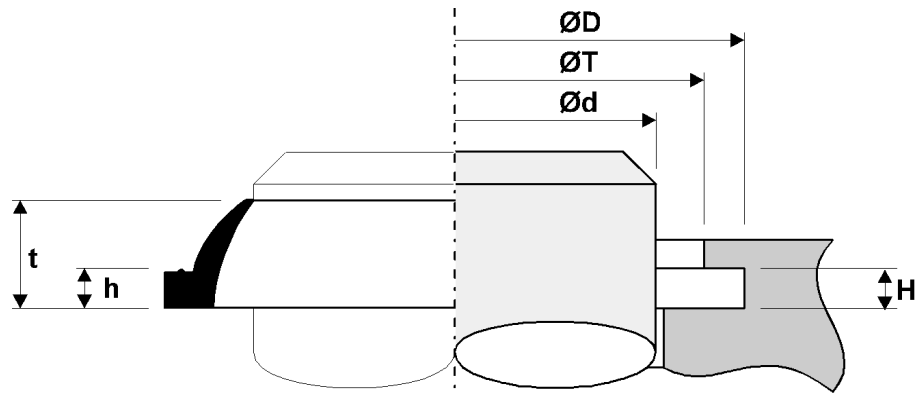

Product Code	Actual Size In Inches				Product Code	Actual Size In Inches			
	Ød	ØD	ØT	H		Ød	ØD	ØT	H
<i>Preferred Range</i>	Nom	+0.010 -0.000	+0.005 -0.005	+0.010 -0.000	<i>Preferred Range</i>	Nom	+0.010 -0.000	+0.005 -0.005	+0.010 -0.000
WO0500	0.500	0.910	0.700	0.135	WO3250	3.250	4.010	3.650	0.197
WO0625	0.625	1.035	0.825	0.135	WO3375	3.375	4.135	3.775	0.197
WO0750	0.750	1.160	0.950	0.135	WO3500	3.500	4.260	3.900	0.197
WO0875	0.875	1.285	1.075	0.135	WO3750	3.750	4.510	4.150	0.197
WO1000	1.000	1.410	1.200	0.135	WO4000	4.000	4.760	4.400	0.197
WO1125	1.125	1.635	1.425	0.135	WO4250	4.250	5.010	4.650	0.197
WO1250	1.250	1.760	1.550	0.135	WO4500	4.500	5.260	4.900	0.197
WO1375	1.375	1.885	1.675	0.135	WO4750	4.750	5.510	5.150	0.197
WO1500	1.500	2.010	1.800	0.135	WO4875	4.875	5.635	5.275	0.197
WO1625	1.625	2.135	1.925	0.135	WO5000	5.000	5.760	5.400	0.197
WO1750	1.750	2.260	2.050	0.135	WO5500	5.500	6.260	5.900	0.197
WO1875	1.875	2.385	2.175	0.135	WO5750	5.750	6.510	6.150	0.197
WO2000	2.000	2.510	2.300	0.135	WO6000	6.000	6.760	6.400	0.197
WO2125	2.125	2.635	2.425	0.135	WO6250	6.250	7.260	6.750	0.260
WO2250	2.250	2.760	2.550	0.135	WO6500	6.500	7.510	7.000	0.260
WO2375	2.375	2.885	2.675	0.135	WO7000	7.000	8.010	7.500	0.260
WO2500	2.500	3.010	2.800	0.135	WO7500	7.500	8.510	8.000	0.260
WO2750	2.750	3.260	3.050	0.135	WO8000	8.000	9.010	8.500	0.260
WO2875	2.875	3.385	3.175	0.135	WO8250	8.250	9.260	8.750	0.260
WO3000	3.000	3.510	3.300	0.135	WO9500	9.500	10.760	10.125	0.322
WO3125	3.125	3.885	3.525	0.197					

Snap-In PTFE Rod Scrapers : Style Z

- Temperature Range :
-40°C to +205°C *
* dependent on energizer selection
- Reciprocating Speed :
Up To 15 m/sec
- Very Low Friction
- Simple Groove Design
- Compatible With a Wide Range Of Fluids
- Service Applications :
Heavy To Severe

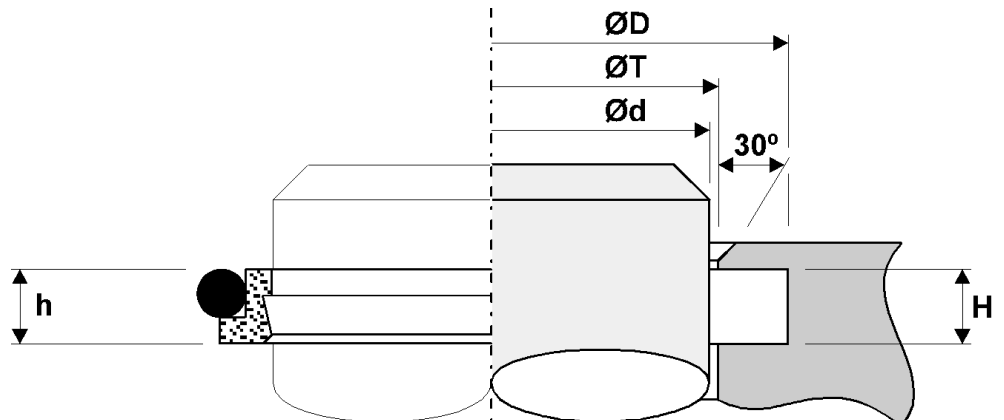



Phone (08) 9451 6011

Fax (08) 9458 5766

**Ensure Availability Before
Machining Or Design**

Light To Medium Duty

Snap-In Rod Scrapers : Style CSW

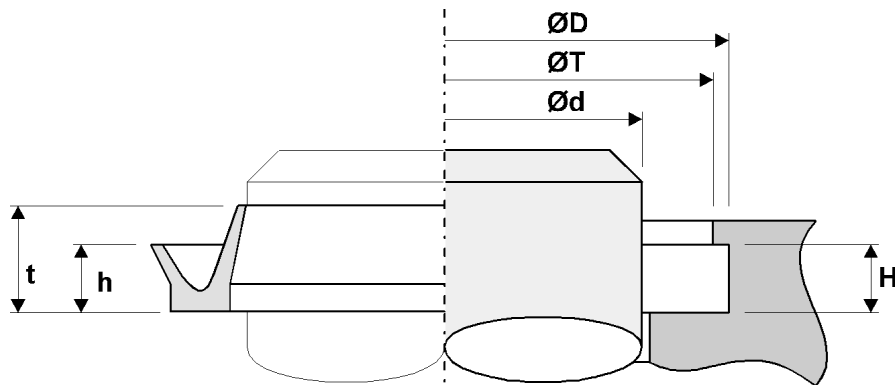

Product Code	Actual Size In Inches				Product Code	Actual Size In Inches			
	Ød	ØD	ØT	H		Ød	ØD	ØT	H
	Nom	+0.005 -0.000	+0.005 -0.000	+0.010 -0.000		Nom	+0.005 -0.000	+0.005 -0.000	+0.010 -0.000
CSW050	0.500	0.875	0.812	0.172	CSW275	2.750	3.250	3.187	0.234
CSW062	0.625	1.000	0.938	0.172	CSW300	3.000	3.500	3.437	0.234
CSW075	0.750	1.250	1.187	0.234	CSW325	3.250	3.750	3.687	0.234
CSW087	0.875	1.375	1.312	0.234	CSW350	3.500	4.000	3.937	0.234
CSW100	1.000	1.500	1.437	0.234	CSW375	3.750	4.250	4.125	0.234
CSW112	1.125	1.625	1.562	0.234	CSW400	4.000	4.500	4.375	0.234
CSW125	1.250	1.750	1.687	0.234	CSW450	4.500	5.000	4.937	0.234
CSW137	1.375	1.875	1.812	0.234	CSW487	4.875	5.375	5.125	0.234
CSW150	1.500	2.000	1.937	0.234	CSW500	5.000	5.500	5.375	0.234
CSW162	1.625	2.125	2.062	0.234	CSW550	5.500	6.125	6.000	0.234
CSW175	1.750	2.250	2.187	0.234	CSW600	6.000	6.500	6.375	0.234
CSW200	2.000	2.500	2.437	0.234	CSW700	7.000	7.625	7.500	0.234
CSW225	2.250	2.750	2.687	0.234	CSW900	9.000	9.625	9.500	0.234
CSW250	2.500	3.000	2.937	0.234					

Snap-In Rod Scrapers : Style CSWM

Product Code	Actual Size In mm				Product Code	Actual Size In mm			
	Ød	ØD	ØT	H		Ød	ØD	ØT	H
	Nom	+0.10 -0.00	+0.10 -0.00	+0.25 -0.00		Nom	+0.10 -0.00	+0.10 -0.00	+0.25 -0.00
CSWM16	16.00	26.00	24.50	4.50	CSWM45	45.00	58.00	56.50	6.00
CSWM20	20.00	33.00	31.50	6.00	CSWM50	50.00	63.00	61.50	6.00
CSWM25	25.00	38.00	36.50	6.00	CSWM80	80.00	93.00	91.50	6.00
CSWM36	36.00	49.00	37.50	6.00	CSWM100	100.00	113.00	111.50	6.00
CSWM40	40.00	53.00	51.50	6.00					



Phone (08) 9451 6011

Fax (08) 9458 5766

**Ensure Availability Before
Machining Or Design**

Light To Medium Duty

Snap-In Rod Wipers : Style MW

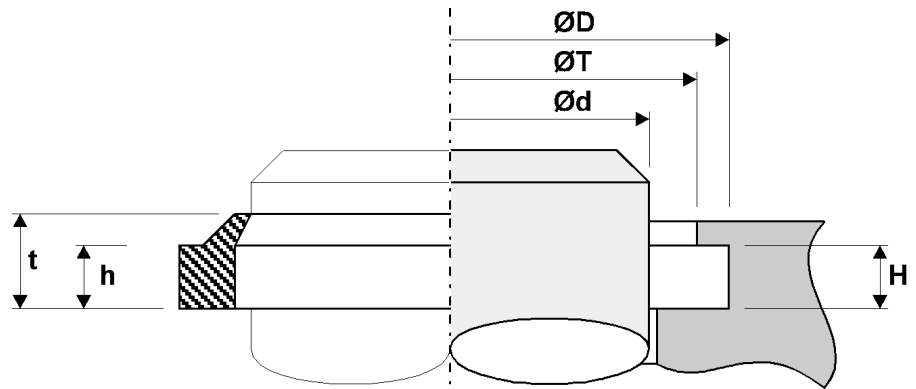

Product Code	Actual Size In mm				Product Code	Actual Size In mm			
	Ød	ØD	ØT	H		Ød	ØD	ØT	H
<i>Preferred Range</i>	Nom	+0.20 -0.00	+0.20 -0.20	+0.10 -0.00	<i>Preferred Range</i>	Nom	+0.20 -0.00	+0.20 -0.20	+0.10 -0.00
MW047070	12.00	18.60	15.00	3.80	MW216248	55.00	63.60	58.00	5.30
MW059082	15.00	21.60	18.00	3.80	MW216255	55.00	65.60	59.00	5.30
MW066094	17.00	23.60	20.00	3.80	MW220251	56.00	64.60	59.00	5.30
MW070094	18.00	24.60	21.00	3.80	MW220259	56.00	66.60	60.00	5.30
MW078110	20.00	28.60	23.00	5.30	MW236267	60.00	68.60	63.00	5.30
MW086118	22.00	30.60	25.00	5.30	MW248279	63.00	71.60	66.00	5.30
MW094125	24.00	32.60	27.00	5.30	MW255287	65.00	73.60	68.00	5.30
MW098129	25.00	33.60	28.00	5.30	MW275307	70.00	78.60	73.00	5.30
MW106137	27.00	35.60	30.00	5.30	MW275314	70.00	80.60	73.00	5.30
MW110141	28.00	36.20	31.00	5.30	MW295326	75.00	83.60	78.00	5.30
MW118149	30.00	38.60	33.00	5.30	MW295345	75.00	87.20	81.00	7.10
MW118165	30.00	42.20	36.00	6.00	MW314346	80.00	88.60	83.00	5.30
MW125157	32.00	40.60	35.00	5.30	MW314362	80.00	92.20	86.00	7.10
MW129161	33.00	41.60	36.00	5.30	MW334366	85.00	93.60	88.00	5.30
MW137169	35.00	43.60	38.00	5.30	MW354401	90.00	102.20	96.00	7.10
MW141173	36.00	44.60	39.00	5.30	MW393440	100.00	112.20	106.00	7.10
MW149181	38.00	46.60	41.00	5.30	MW413460	105.00	117.20	111.00	7.10
MW157188	40.00	48.60	43.00	5.30	MW433480	110.00	122.20	116.00	7.10
MW177208	45.00	53.60	48.00	5.30	MW472519	120.00	132.20	126.00	7.10
MW181212	46.00	54.60	49.00	5.30	MW492551	125.00	140.00	132.60	10.10
MW188220	48.00	56.60	51.00	5.30	MW511559	130.00	142.20	136.00	7.10
MW196228	50.00	58.60	53.00	5.30	MW551598	140.00	152.20	146.00	7.10
MW196236	50.00	60.60	53.00	5.30	MW708767	180.00	195.20	188.00	10.10

OEM Replacements : Hyva Hoists & Hydrauto Hoists

Product Code	Ød	ØD	ØT	H	Product Code	Ød	ØD	ØT	H
WRM236275	60.00	70.00	66.00	6.00	KW45	45.00	53.00	49.00	5.00
WRM307346	78.00	88.00	84.00	6.00	KW60	60.00	68.00	64.00	5.00
WRM390429	99.00	109.00	105.00	6.00	KW75	75.00	83.00	79.00	5.00
WRM472511	120.00	130.00	126.00	6.00	KW90	90.00	98.00	94.00	5.00
WRM555594	141.00	151.00	147.00	6.00	KW105	105.00	113.00	109.00	5.00
WRM638677	162.00	172.00	168.00	6.00	KW120	120.00	128.00	124.00	5.00
WRM720759	183.00	193.00	189.00	6.00	KW140	140.00	148.00	144.00	5.00
WRM815854	207.00	217.00	213.00	6.00	KW160	160.00	168.00	164.00	5.00
WRM909948	231.00	241.00	237.00	6.00	KW170	170.00	178.00	174.00	5.00
					KW180	180.00	188.00	184.00	5.00
					KW205	205.00	213.00	209.00	5.00



Phone (08) 9451 6011

Fax (08) 9458 5766

**Ensure Availability Before
Machining Or Design**

Light To Medium Duty

Snap-In Rod Wipers : Style AA

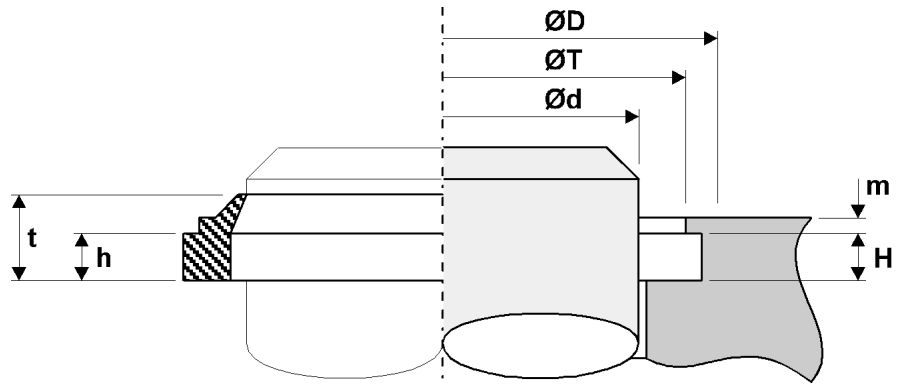

Product Code	Actual Size In mm					
	Ød +0.10 Nominal	ØD +0.15 Nominal	ØT +0.20 -0.00	H -0.00	m -0.20	t Nominal
AA1218	12.00	18.00	16.00	2.60	1.00	5.00
AA1220	12.00	20.00	18.00	4.00	1.00	7.00
AA1523	15.00	23.00	21.00	4.00	1.00	7.00
AA1624	16.00	24.00	22.00	4.00	1.00	7.00
AA1826	18.00	26.00	24.00	4.00	1.00	7.00
AA2028	20.00	28.00	26.00	4.00	1.00	7.00
AA2230	22.00	30.00	28.00	4.00	1.00	7.00
AA2533	25.00	33.00	31.00	4.00	1.00	7.00
AA2836	28.00	36.00	34.00	4.00	1.00	7.00
AA3038	30.00	38.00	36.00	4.00	1.00	7.00
AA3240	32.00	40.00	38.00	4.00	1.00	7.00
AA3543	35.00	43.00	41.00	4.00	1.00	7.00
AA3644	36.00	44.00	42.00	4.00	1.00	7.00
AA4048	40.00	48.00	46.00	4.00	1.00	7.00
AA4250	42.00	50.00	48.00	4.00	1.00	7.00
AA4553	45.00	53.00	51.00	4.00	1.00	7.00
AA5058	50.00	58.00	56.00	4.00	1.00	7.00
AA5563	55.00	63.00	61.00	4.00	1.00	7.00
AA5664	56.00	64.00	62.00	4.00	1.00	7.00
AA6068	60.00	68.00	66.00	4.00	1.00	7.00
AA6371	63.00	71.00	69.00	4.00	1.00	7.00
AA6573	65.00	73.00	71.00	4.00	1.00	7.00
AA7078	70.00	78.00	76.00	4.00	1.00	7.00
AA8088	80.00	88.00	86.00	4.00	1.00	7.00
AA9098	90.00	98.00	96.00	4.00	1.00	7.00
AA100108	100.00	108.00	106.00	4.00	1.00	7.00
AA110122	110.00	122.00	117.00	5.50	1.50	10.00
AA120132	120.00	132.00	129.00	5.50	1.50	10.00
AA125137	125.00	137.00	134.00	5.50	1.50	10.00
AA140152	140.00	152.00	149.00	5.50	1.50	10.00
AA160172	160.00	172.00	169.00	5.50	1.50	10.00
AA200212	200.00	212.00	209.00	5.50	1.50	10.00



Snap-In Rod Wipers : Style JDH

Ensure Availability Before
Machining Or Design

Light To Medium Duty

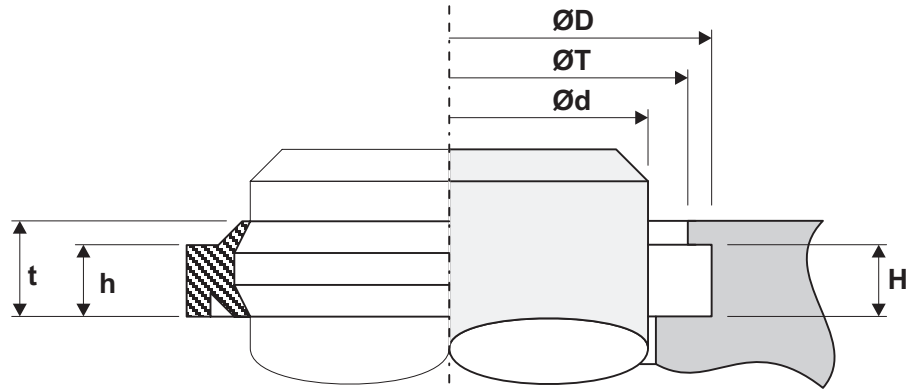

Code	Actual Size In mm				Code	Actual Size In mm			
	Ød +0.10 Nom	ØD +0.30 H11	ØT -0.10	H -0.00		Ød +0.10 Nom	ØD +0.30 H11	ØT -0.10	H -0.00
JDH25	25.00	33.00	29.30	5.00	JDH60	60.00	68.00	64.00	6.00
JDH30	30.00	38.00	34.00	6.00	JDH63	63.00	71.00	67.00	6.00
JDH31-5	31.50	39.50	35.50	6.00	JDH70	70.00	80.00	75.00	7.00
JDH35	35.00	43.00	39.00	6.00	JDH75	75.00	85.00	80.00	7.00
JDH40	40.00	48.00	44.00	6.00	JDH80	80.00	90.00	85.00	7.00
JDH45	45.00	53.00	49.00	6.00	JDH90	90.00	100.00	95.00	7.00
JDH50	50.00	58.00	54.00	6.00	JDH100	100.00	110.00	105.00	7.00
JDH55	55.00	63.00	59.00	6.00	JDH125	125.00	138.00	132.00	8.00

Transeals Pty Ltd

ABN 29 008 902 163

1 Atlas Court, Welshpool, Western Australia, 6106

PO Box 15, Welshpool, Western Australia, 6986

Phone: 61 (08) 9451 6011 E-mail: transeals@transeals.com.au

Fax: 61 (08) 9458 5766 Web: <http://www.transeals.com.au>

