

- Category**
- Seal, Single Acting Rod or Piston
- Construction**
- NBR symmetrical U-ring
- Housing**
- Rectangular groove in one piece gland or piston
- Duty**
- Light
- Comments**
- Homogeneous NBR U-ring suitable for pneumatic or light duty hydraulic applications
- Size Range**
- Imperial

Metric Specifications

Operating Conditions	Maximum Speed:	0.5 m/sec
	Temperature Range:	-40°C ~ 80°C
Surface Finish	Dynamic Sealing Face:	0.1 ~ 0.4 µmRa
	Static Sealing Face:	1.6 µmRa max
	Other Faces:	3.2 µmRa max
Chamfers	Minimum Z = C x 0.85 where C = (ØD - Ød) ÷ 2	

Imperial Specifications

Operating Conditions	Maximum Speed:	1.5 ft/sec
	Temperature Range:	-40 ~ 180°F
Surface Finish	Dynamic Sealing Face:	4 ~ 16 µinCLA
	Static Sealing Face:	63 µinCLA max
	Other Faces:	125 µinCLA max
Chamfers	Minimum Z = C x 0.85 where C = (ØD - Ød) ÷ 2	

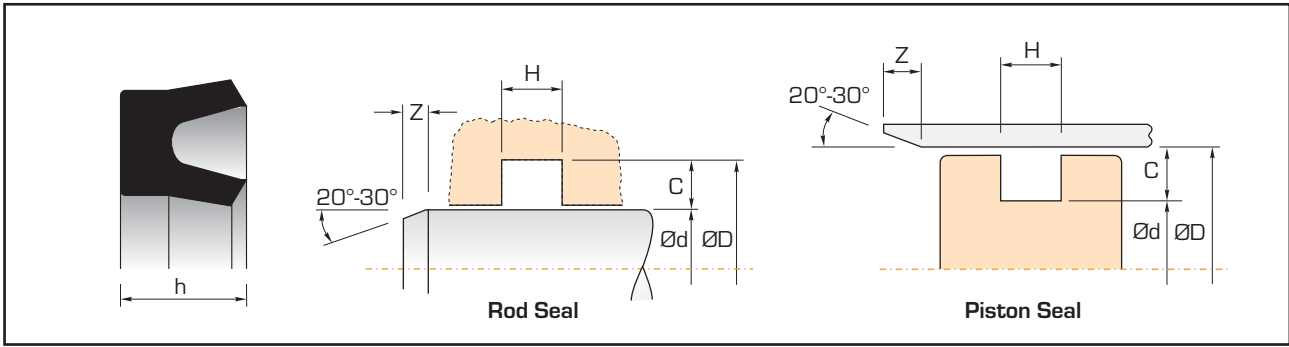

Imperial Sizes

Part No.	Ød	ØD	H	h
<i>Rod</i>	<i>f9</i>	<i>JS11</i>	<i>+0.010 -0</i>	
<i>Piston</i>	<i>js11</i>	<i>H9</i>	<i>+0.010 -0</i>	
8404-0025-N8	0.250	0.500	0.156	0.125
8404-0037-N8	0.375	0.625	0.156	0.125
8404-0050-N8	0.500	0.750	0.156	0.125
8404-0062-N8	0.625	0.875	0.156	0.125
8404-0075-N8	0.750	1.000	0.156	0.125
8404-0087-N8	0.875	1.125	0.156	0.125
8404-0100-N8	1.000	1.250	0.156	0.125
8405-0100-N8	1.000	1.312	0.188	0.156
8408-0100-N8	1.000	1.500	0.281	0.250
8405-0106-N8	1.062	1.375	0.188	0.156
8404-0112-N8	1.125	1.375	0.156	0.125
8405-0118-N8	1.187	1.500	0.188	0.156
8405-0125-N8	1.250	1.562	0.188	0.156
8405-0131-N8	1.312	1.625	0.188	0.156
8405-0137-N8	1.375	1.687	0.188	0.156
8406-0137-N8	1.375	1.750	0.219	0.187
8405-0150-N8	1.500	1.812	0.188	0.156
8406-0150-N8	1.500	1.875	0.219	0.187
8406-0162-N8	1.625	2.000	0.219	0.187
8406-0175-N8	1.750	2.125	0.219	0.187
8406-0187-N8	1.875	2.250	0.219	0.187
8406-0200-N8	2.000	2.375	0.219	0.187
8406-0212-N8	2.125	2.500	0.219	0.187
8406-0225-N8	2.250	2.625	0.219	0.187
8406-0237-N8	2.375	2.750	0.219	0.187
8407-0250-N8	2.500	2.937	0.250	0.218
8407-0256-N8	2.562	3.000	0.250	0.218
8406-0275-N8	2.750	3.125	0.219	0.187
8407-0275-N8	2.750	3.187	0.250	0.218
8408-0275-N8	2.750	3.250	0.281	0.250
8407-0281-N8	2.812	3.250	0.250	0.218
8407-0300-N8	3.000	3.437	0.250	0.218
8407-0306-N8	3.062	3.500	0.250	0.218

Imperial Sizes (cont'd)

Part No.	Ød	ØD	H	h
8408-0350-N8	3.500	4.000	0.281	0.250
8408-0400-N8	4.000	4.500	0.281	0.250
8409-0443-N8	4.437	5.000	0.312	0.281
8408-0450-N8	4.500	5.000	0.281	0.250
8410-0537-N8	5.375	6.000	0.344	0.312
8509-0543-N8	5.437	6.000	0.312	0.281
8410-0637-N8	6.375	7.000	0.344	0.312
8410-0737-N8	7.375	8.000	0.344	0.312
8411-0931-N8	9.312	10.000	0.375	0.343
8412-1125-N8	11.250	12.000	0.406	0.375
8416-1300-N8	13.000	14.000	0.531	0.500
8413-1318-N8	13.188	14.000	0.438	0.406