

**Category**

- Seal, Single Acting Rod

**Construction**

- Ribbed NBR sealing section with polymer header ring and acetal antiextrusion ring

**Housing**

- Rectangular groove in two piece gland

**Duty**

- Heavy

**Features**

- Ribbed sealing element cushions pressure spikes
- Pressure activated contoured back up washer and antiextrusion ring support the sealing element

**Comments**

- Designed specifically for mobile hydraulics

**Size Range**

- Metric and imperial

**Metric Specifications**

**Operating Conditions**

Maximum Speed:	0.5 m/sec
Temperature Range:	-40°C ~ 110°C
Maximum Pressure:	400 bar

**Surface Finish**

Dynamic Sealing Face:	0.1 ~ 0.4 µmRa
Static Sealing Face:	1.6 µmRa max
Other Faces:	3.2 µmRa max

**Extrusion Gap (Diametral)**

Pressure (bar)	160	250	400
Maximum gap (mm)	0.60	0.50	0.40

**Chamfer**

Minimum Z = C x 0.85	where C = (ØD - Ød) ÷ 2
----------------------	-------------------------

**Imperial Specifications**

**Operating Conditions**

Maximum Speed:	1.5 ft/sec
Temperature Range:	-22°F ~ 212°F
Maximum Pressure:	6000 psi

**Surface Finish**

Dynamic Sealing Face:	4 ~ 16 µinCLA
Static Sealing Face:	63 µinCLA max
Other Faces:	125 µinCLA max

**Extrusion Gap (Diametral)**

Pressure (psi)	2400	3750	6000
Maximum gap (in)	0.024	0.016	0.010

**Chamfer**

Minimum Z = C x 0.85	where C = (ØD - Ød) ÷ 2
----------------------	-------------------------

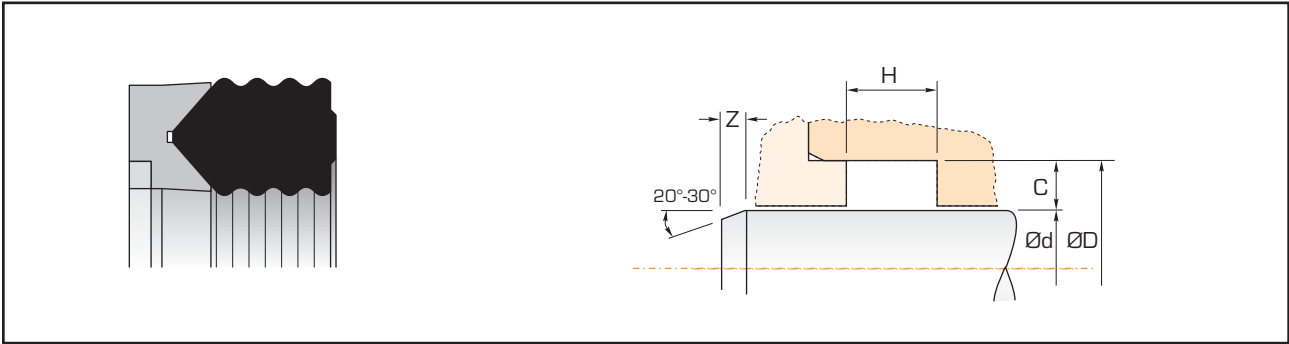

## Metric Sizes

Part No	Ød	ØD	H
<i>Rod</i>	<i>f8</i>	<i>JS11</i>	<i>+0.25 -0</i>
SM3522-20HD	22.00	35.00	20.00
SM4128-20HD	28.00	41.00	20.00
SM4732-22.5HD	32.00	47.00	22.50
SM5035-22.5HD	35.00	50.00	22.50
SM5136-22.5HD	36.00	51.00	22.50
SM5240-22.5HD	40.00	52.00	22.50
SM5540-22.6HD	40.00	55.00	22.60
SM6040-30HD	40.00	60.00	30.00
SM6045-22.5HD	45.00	60.00	22.50
SM6545-28HD	45.00	65.00	28.00
SM6350-20HD	50.00	63.00	20.00
SM6550-22.5HD	50.00	65.00	22.50
SM7050-30HD	50.00	70.00	30.00
SM7055-22.5HD	55.00	70.00	22.50
SM7555-30HD	55.00	75.00	30.00
SM7560-22.5HD	60.00	75.00	22.50
SM7760-27HD	60.00	77.00	27.00
SM8060-32HD	60.00	80.00	32.00
SM8060-34.9HD	60.00	80.00	34.90
SM8363-27HD	63.00	83.00	27.00
SM8363-29HD	63.00	83.00	29.00
SM8565-29HD	65.00	85.00	29.00
SM8370-25HD	70.00	83.00	25.00
SM8570-22.5HD	70.00	85.00	22.50
SM9070-30HD	70.00	90.00	30.00
SM96.576.5-32.5HD	76.50	96.50	32.50
SM10080-30HD	80.00	100.00	30.00
SM11090-30HD	90.00	110.00	30.00
SM120100-30HD	100.00	120.00	30.00
SM130110-32.5HD	110.00	130.00	32.50
SM140120-30HD	120.00	140.00	30.00
SM160140-28HD	140.00	160.00	28.00
SM170150-28HD	150.00	170.00	28.00
SM205180-35HD	180.00	205.00	35.00
SM215190-35HD	190.00	215.00	35.00
SM225200-35HD	200.00	225.00	35.00

## Imperial Sizes

Part No	Ød	ØD	H
<i>Rod</i>	<i>f8</i>	<i>JS11</i>	<i>+0.010 -0</i>
S150100-075HD	1.000	1.500	0.765
S175125-075HD	1.250	1.750	0.765
S200150-075HD	1.500	2.000	0.765
S250200-085HD	2.000	2.500	0.865
S262200-098HD	2.000	2.625	0.995
S300250-087HD	2.500	3.000	0.890
S325250-104HD	2.500	3.250	1.062
S325250-123HD	2.500	3.250	1.245
S350275-131HD	2.750	3.500	1.327
S350300-100HD	3.000	3.500	1.015
S375300-097HD	3.000	3.750	0.985
S375300-131HD	3.000	3.750	1.327
S400350-087HD	3.500	4.000	0.890
S425350-130HD	3.500	4.250	1.307
S500400-150HD	4.000	5.000	1.515